

CONSTRUCTION

- Top constructed of 1-1/8" particleboard with thermally fused melamine surface on both sides
- Thermally fused 3mm PVC edge banding
- Lower open shelf constructed of 3/4" particleboard with thermally fused melamine surface on both sides
- 14-gauge steel legs mounted on a 12-gauge steel plate with powder-coat finish
- 16-gauge steel support bars with powder-coat finish
- 5" heavy duty swivel casters

FINISHES

WORKSURFACE/ BASE LAMINATES

Most available with matching edge band.

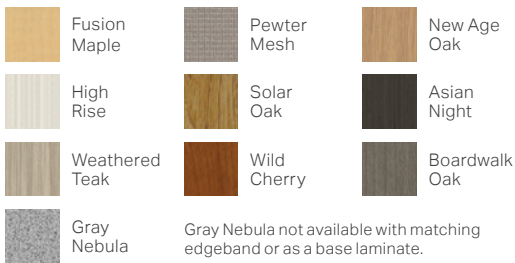

ADDITIONAL (BASE ONLY) LAMINATES

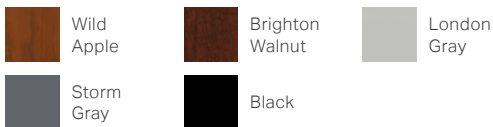

DRY ERASE LAMINATES Available with color edge band.

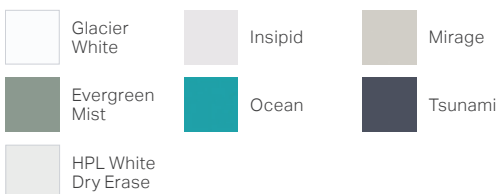

OPTIONAL EDGE BAND COLORS

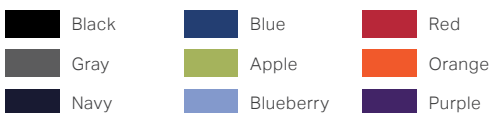

WARRANTY

10 Year Limited

CERTIFICATIONS

Worksurfaces are UL Greenguard Gold certified

DIMENSIONS

Model #	Width	Depth	Height
42A71236	72"	36"	36"

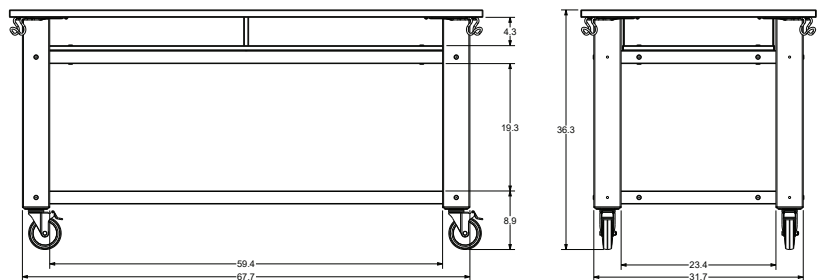
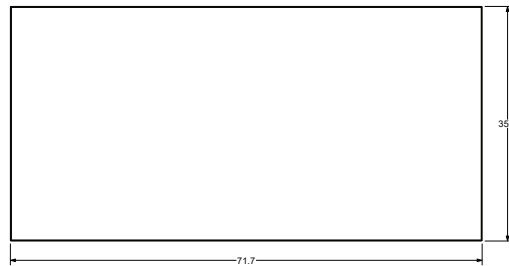
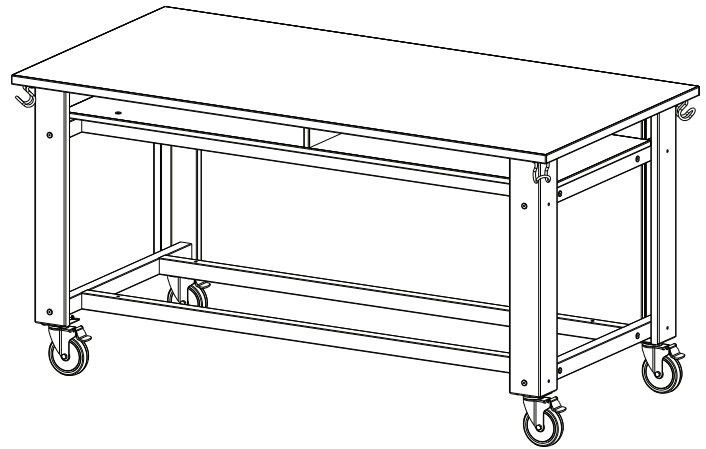

This specification information is provided for general reference only and is subject to change without notice. While every effort has been made to ensure accuracy, Marco makes no warranties, express or implied, regarding the completeness or correctness of the details presented. Users should always verify specifications with the latest product documentation before making any purchasing decisions.

CONSTRUCTION

- Top constructed of 1-1/8" particleboard with thermally fused melamine surface on both sides
- Thermally fused 3mm PVC edge banding
- Lower open shelf constructed of 3/4" particleboard with thermally fused melamine surface on both sides
- 14-gauge steel legs mounted on a 12-gauge steel plate with powder-coat finish
- 16-gauge steel support bars with powder-coat finish
- 5" heavy duty swivel casters
- (4) 3" plastic storage trays with glides
- (2) fixed lower compartment shelves
- (2) adjustable compartment shelves

FINISHES

WORKSURFACE/ BASE LAMINATES

Most available with matching edge band.



ADDITIONAL (BASE ONLY) LAMINATES

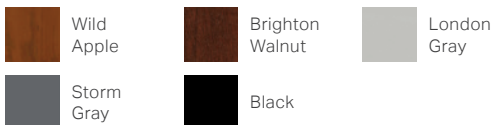

DRY ERASE LAMINATES Available with color edge band.

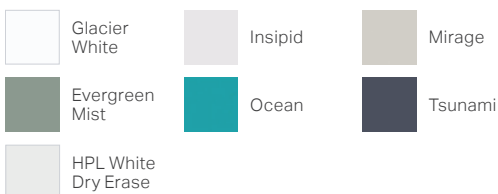

OPTIONAL EDGE BAND COLORS

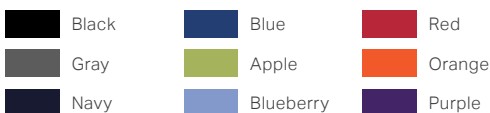

WARRANTY

10 Year Limited

CERTIFICATIONS

Worksurfaces are UL Greenguard Gold certified

DIMENSIONS

Model #	Width	Depth	Height
42A71436	72"	36"	36"

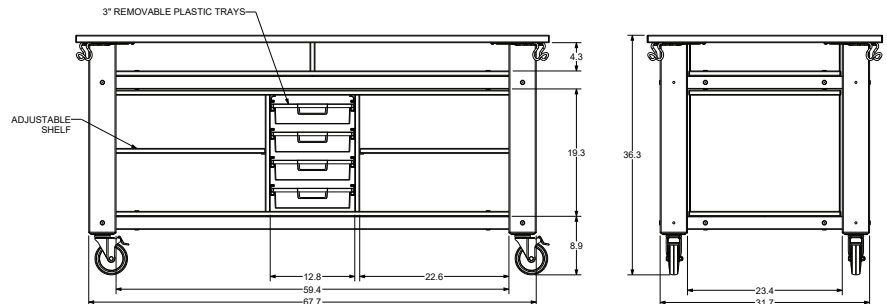
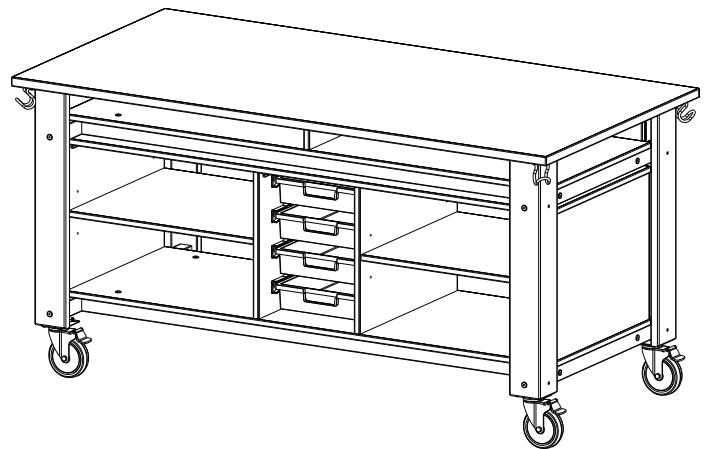

This specification information is provided for general reference only and is subject to change without notice. While every effort has been made to ensure accuracy, Marco makes no warranties, express or implied, regarding the completeness or correctness of the details presented. Users should always verify specifications with the latest product documentation before making any purchasing decisions.

CONSTRUCTION

- Top constructed of 1-1/8" particleboard with thermally fused melamine surface on both sides
- Thermally fused 3mm PVC edge banding
- Lower open shelf constructed of 3/4" particleboard with thermally fused melamine surface on both sides
- 14-gauge steel legs mounted on a 12-gauge steel plate with powder-coat finish
- 16-gauge steel support bars with powder-coat finish
- 5" heavy duty swivel casters
- (3) fixed lower compartment shelves
- (3) adjustable compartment shelves

FINISHES

WORKSURFACE/ BASE LAMINATES

Most available with matching edge band.

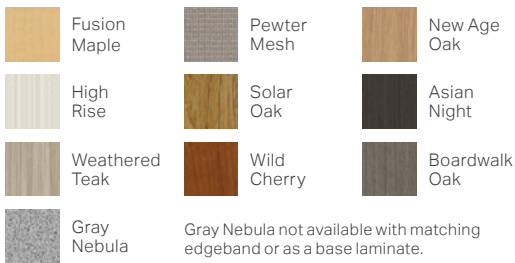

ADDITIONAL (BASE ONLY) LAMINATES

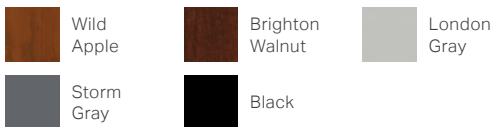

DRY ERASE LAMINATES Available with color edge band.

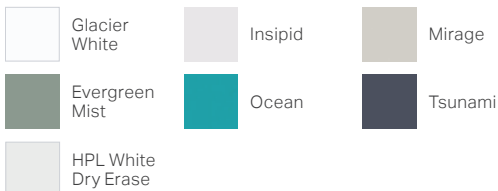

OPTIONAL EDGE BAND COLORS

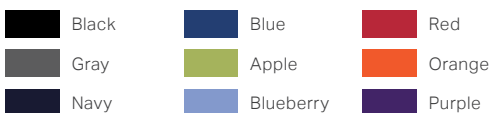

WARRANTY

10 Year Limited

CERTIFICATIONS

Worksurfaces are UL Greenguard Gold certified

DIMENSIONS

Model #	Width	Depth	Height
42A71336	72"	36"	36"

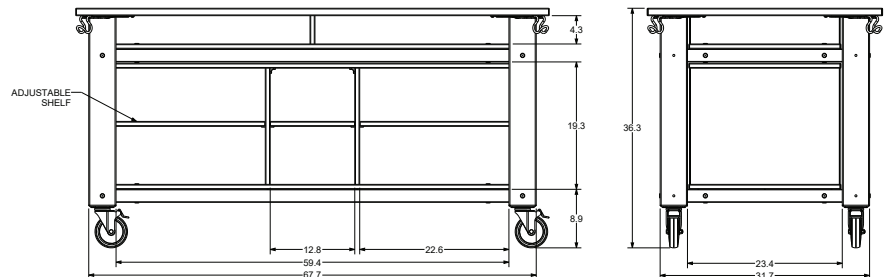
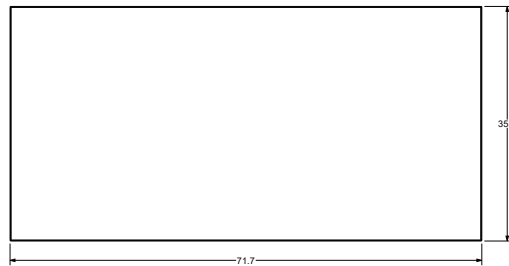
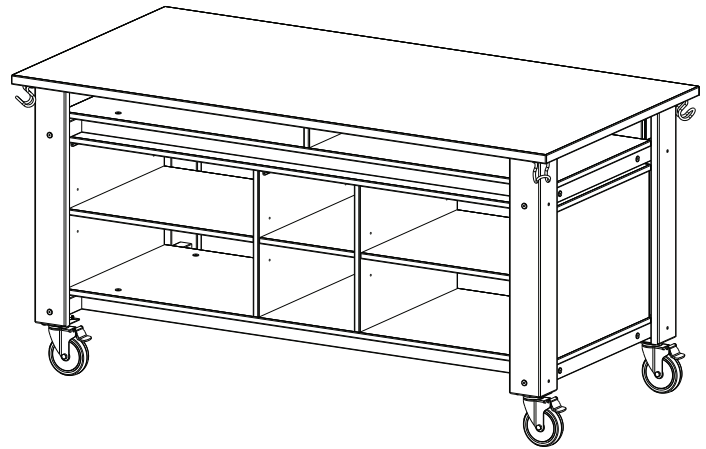

This specification information is provided for general reference only and is subject to change without notice. While every effort has been made to ensure accuracy, Marco makes no warranties, express or implied, regarding the completeness or correctness of the details presented. Users should always verify specifications with the latest product documentation before making any purchasing decisions.