

### Hardware (Included)

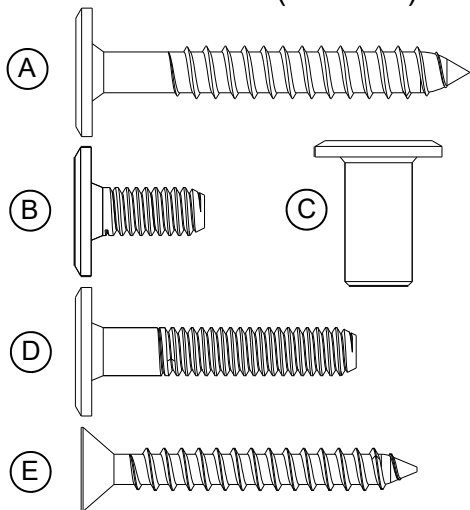

### Hex key (Included)

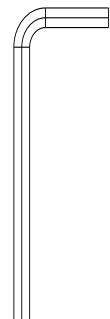

1. Attach casters to cart base using four bolts (B) and cap nuts (C) per caster. Slide caster mount plate under pre-attached plastic trim. Tighten all bolts hand tight only.
2. Attach steel support bar to bottom side of base using screw (E).
3. Attach left and right side uprights to the base using screw (A) as shown leaving the screws loose.
4. Carefully insert the bell support panel between the side uprights aligning the panel with the dados in the side panels. Attach with screw (A) through side panels leaving slightly loose.
5. Attach two upper supports to side panels using screw (A).
6. Tighten all screws with hex key starting with the base and work your way up.
7. Attach vertical back support with two screws (A) to the base, one screw (A) to bell support, and two bolts (D) and cap nuts (C) to the upper supports.

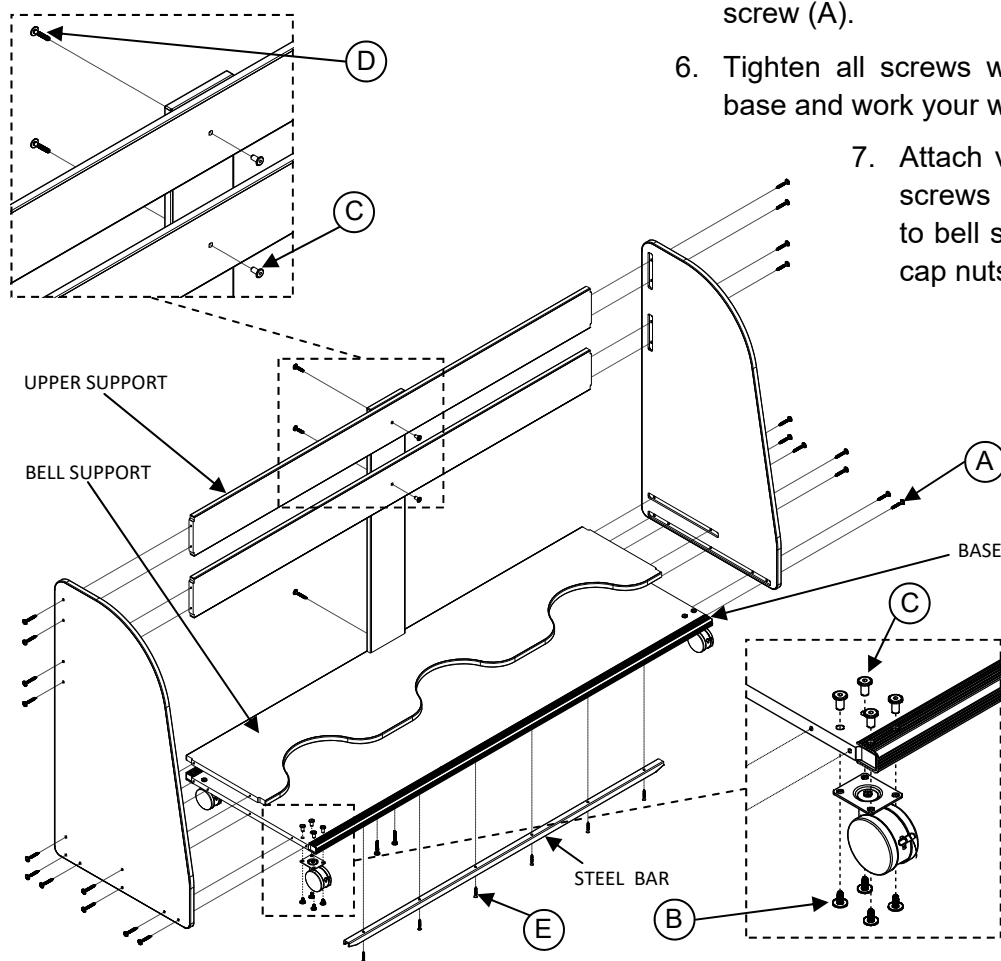

**CAUTION, DO NOT OVER TIGHTEN CASTER BOLTS OR USE POWER TOOLS**

Marco Group, Inc.  
5400 Doniphan Dr.  
Neosho, MO 64850  
www.marcogroupinc.com

Customer Service Hours:  
Monday-Friday 8:30am to 4:30pm CST  
(Except holidays)  
Toll-Free 888-627-2601  
CustomerService@marcogroupinc.com

417-455-9663 - Phone  
417-455-0057 - Fax