



Assembly Instructions

#85323

BS507 Encore Cart

Rev. 07-22-25

Tools required

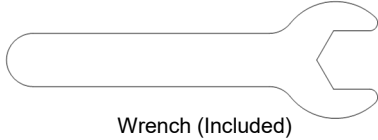

Wrench (Included)

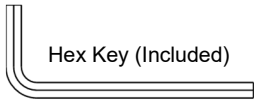

Hex Key (Included)

Hardware (Included)

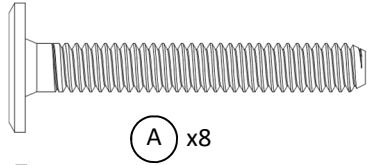

A x8

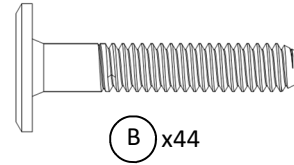

B x44

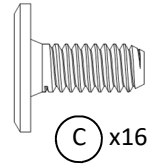

C x16

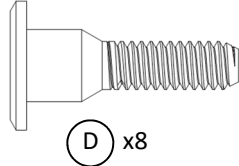

D x8



E x16

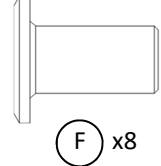

F x8

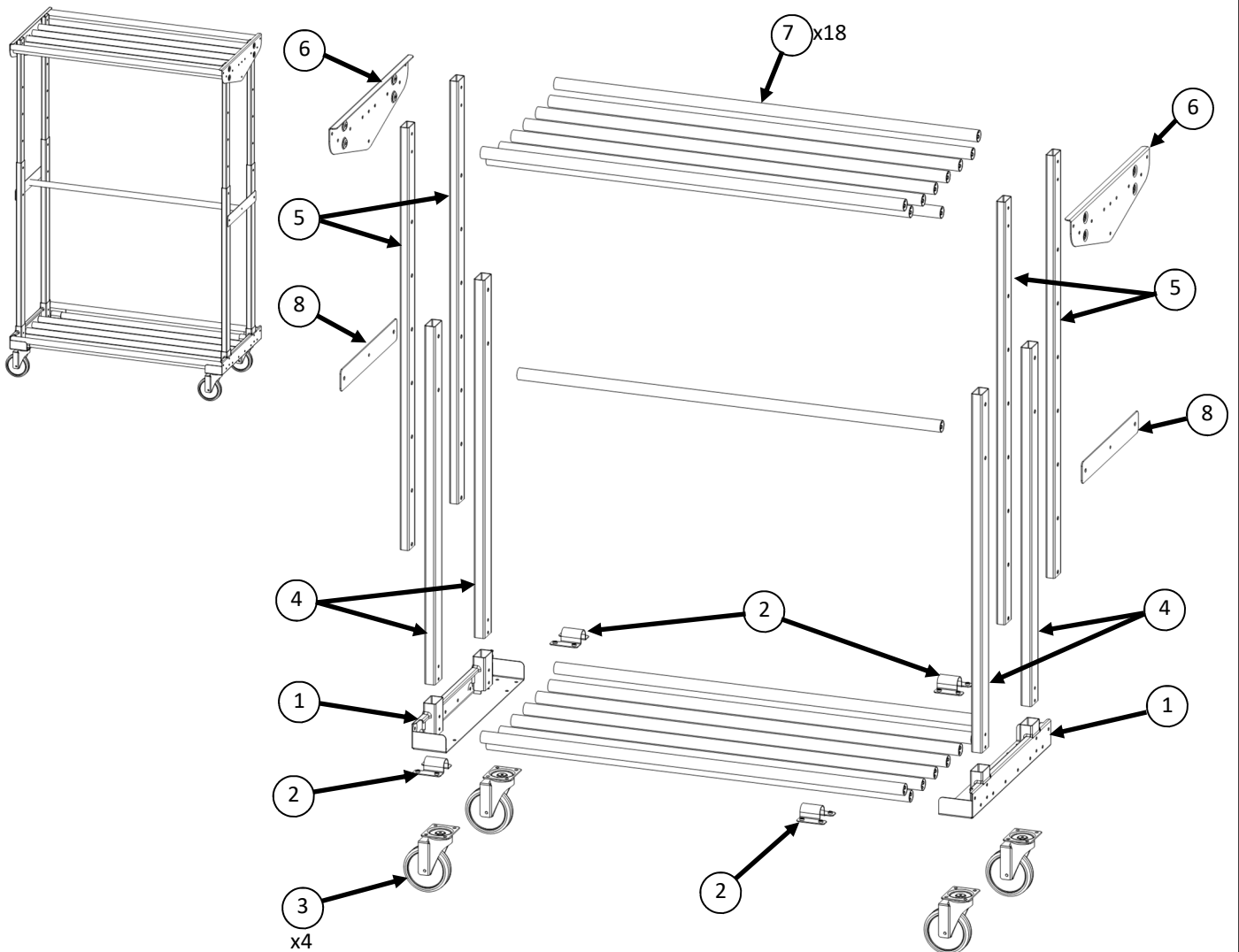

Marco Group, Inc.
 5400 Doniphan Dr.
 Neosho, MO 64850
www.madebymarco.net

Customer Service Hours:
 Monday-Friday 8:30am to 4:30pm CST
 (Except holidays)
 Toll-Free 888-627-2601
CustomerService@marcogroupinc.com

417-455-9663 - Phone
 417-455-0057 - Fax

1

Attach base end caps '1' to eight steel tubes '7' using bolts 'B' as shown.

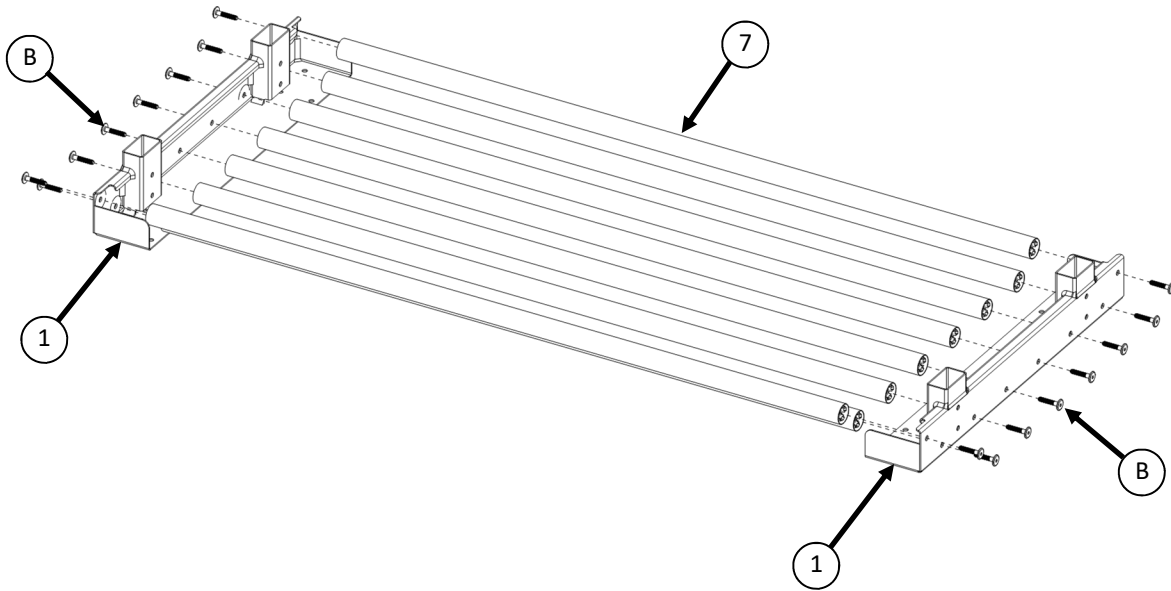

2

Place caster brackets '2' over tubes on base frame and align holes with caster mounting holes.

Attach casters '3' to base frame with four bolts 'C' per caster.

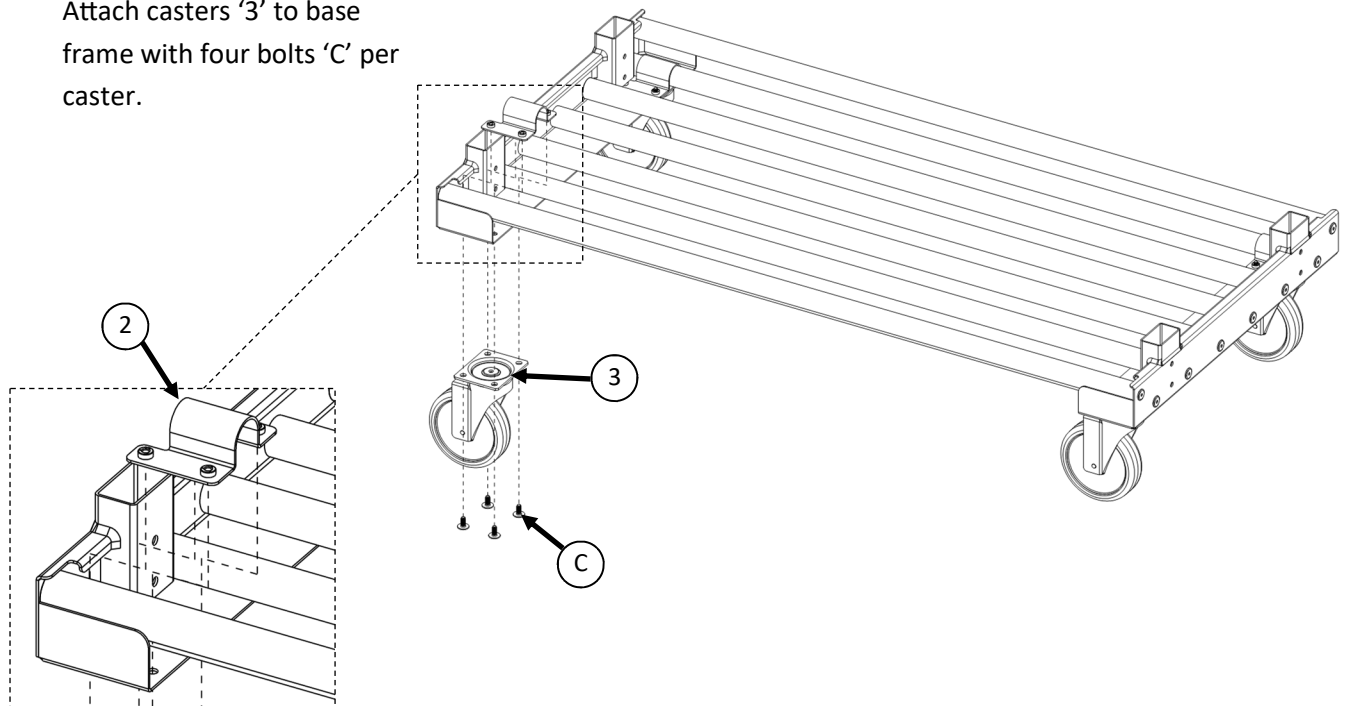

3

Attach upright legs '4' to base frame using two bolts 'A' and two lock-nuts 'E' per leg.

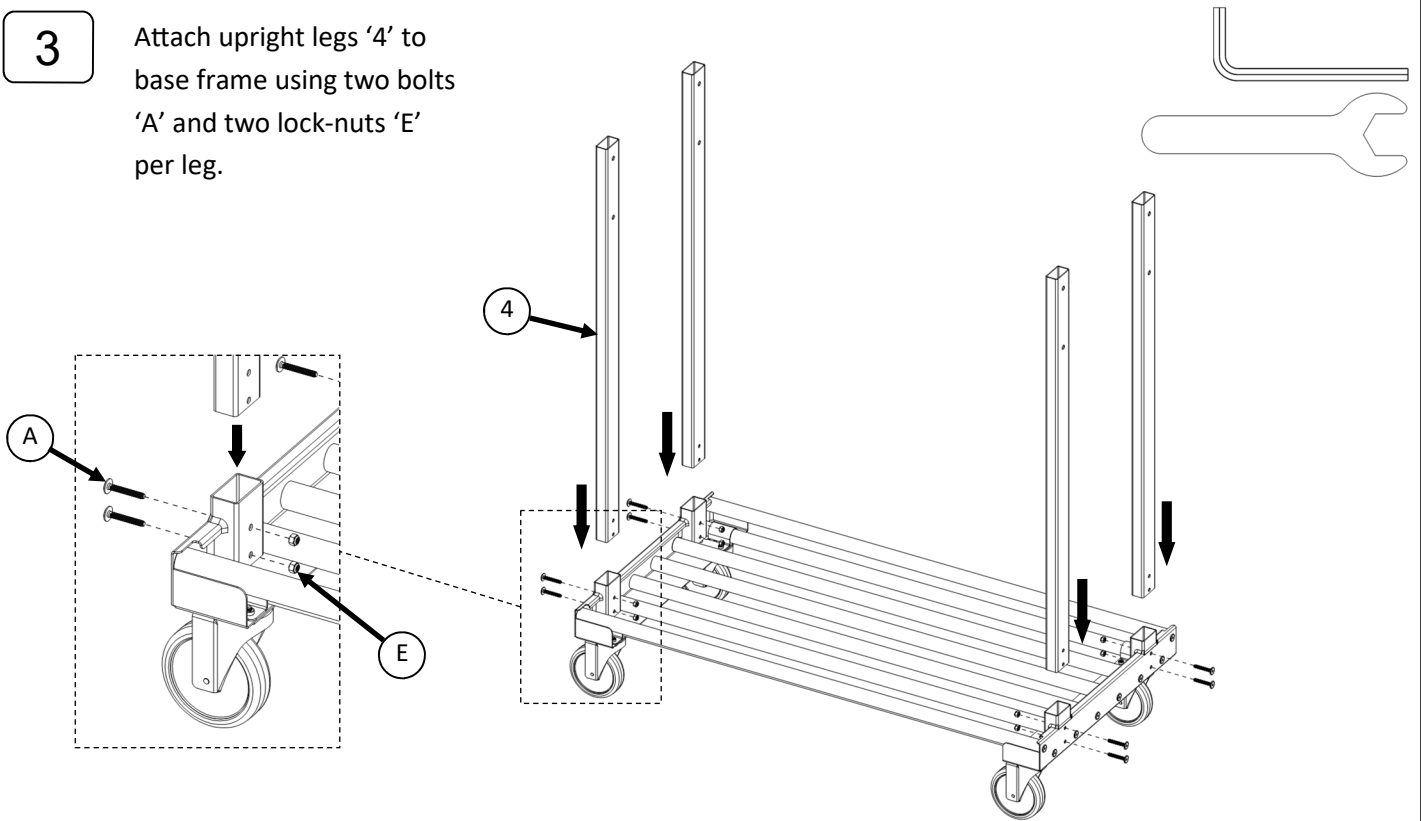

4

Insert upper adjustable upright legs '5' into lower upright legs and set at desired height. Attach using two bolts 'D' and two cap nuts 'F' per leg. At either the top or bottom bolt location attach brace plate '8' to the outside of the legs while bolting the upper leg in place.

OPTION: Attach optional middle hanger bar between brace plates using two bolts 'B'. If middle bar is not needed it can be stored on the top shelf using the extra hole on the top shelf end plates.

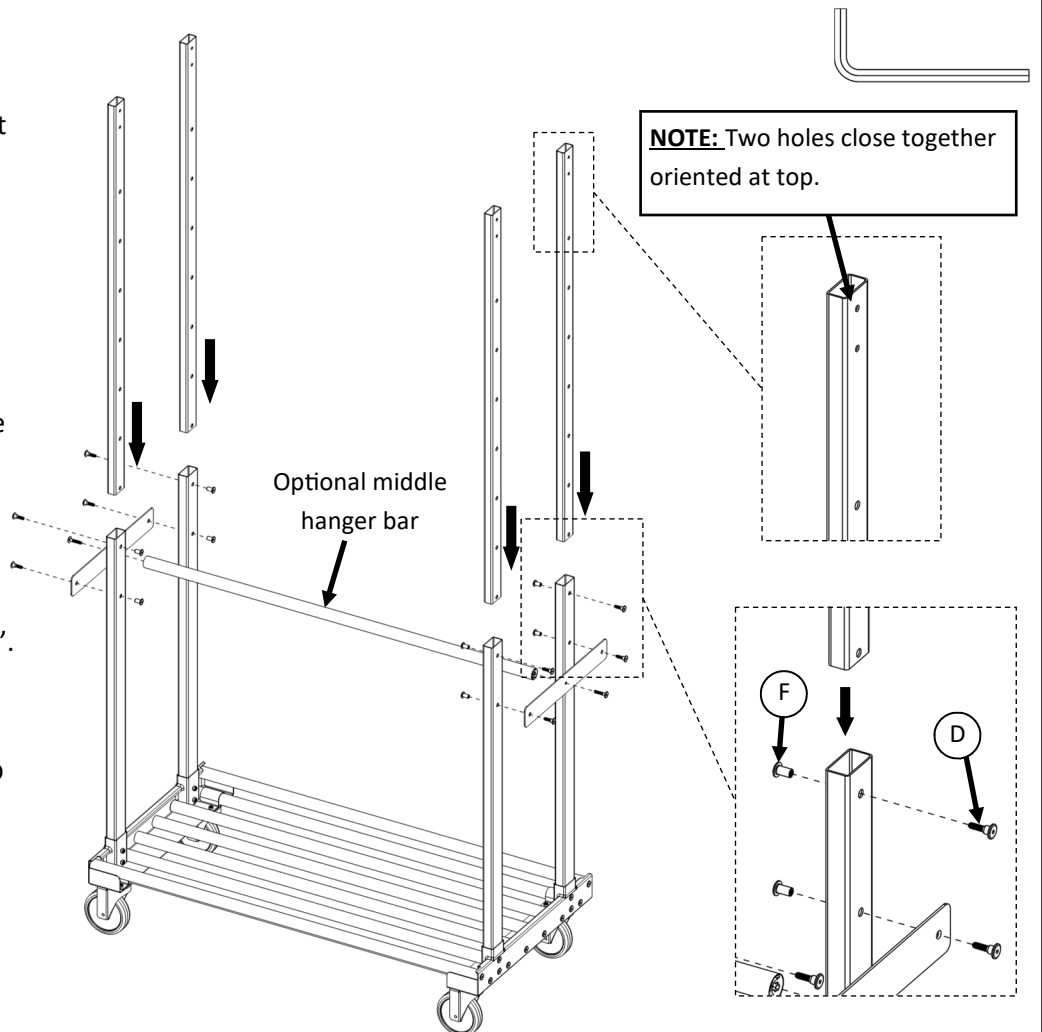

5

Attach top shelf end plates '6' to nine steel tubes '7' using bolt 'B'.

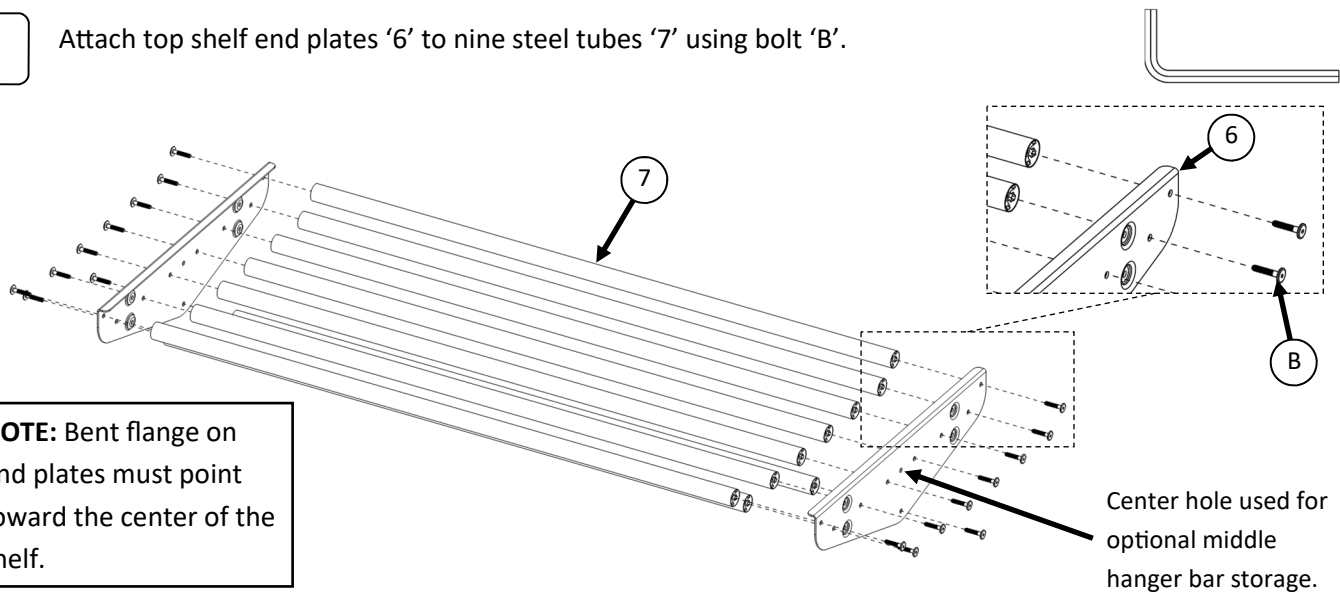

6

Attach top shelf to upper upright legs using eight bolts 'B' and lock-nuts 'E'.

