

### Tools required

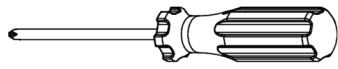

#2 Phillips Screwdriver

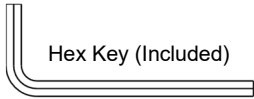

Hex Key (Included)

### Hardware (Included)



(A) x12

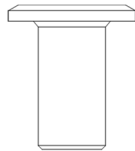

(B) x16

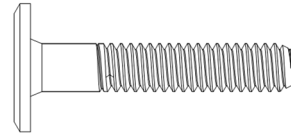

(C) x16

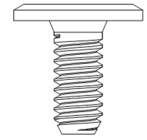

(D) x32

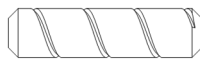

(E) x8

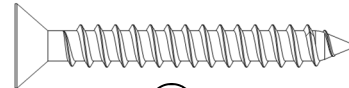

(F) x8

There are two versions of this unit - 30" high and 42" high. The 42" high version is used for the illustrations. Assembly is the same for both versions.

30" High 42A61030

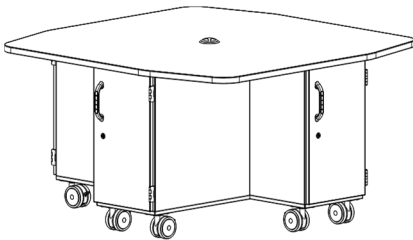

42" High 42A61042

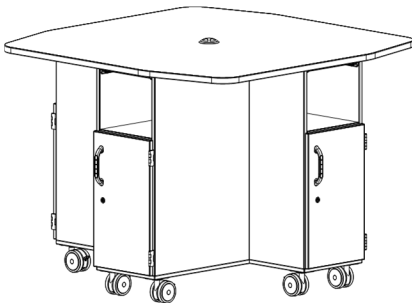

Optional power module 4 Models without optional power module will not have center hole

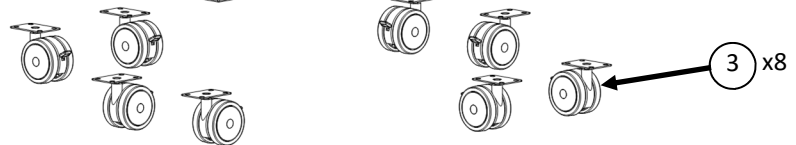
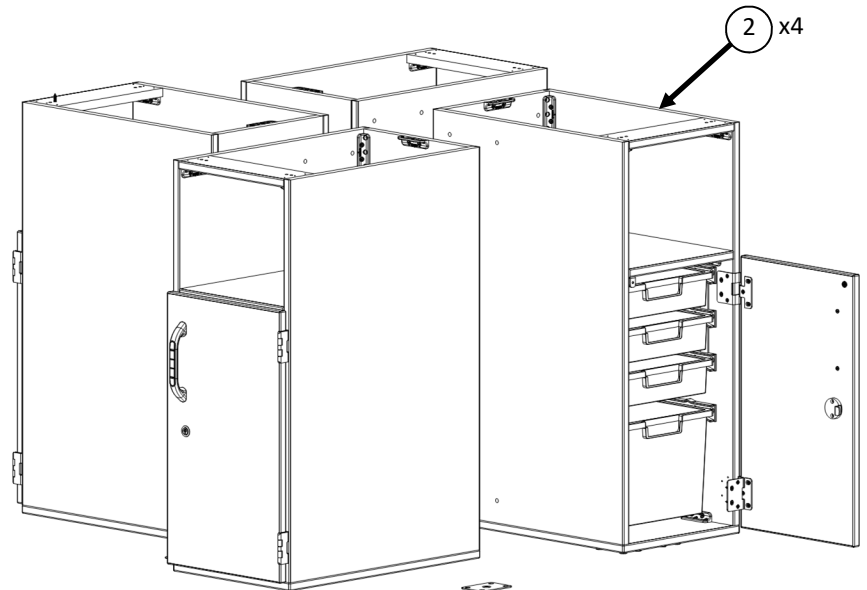
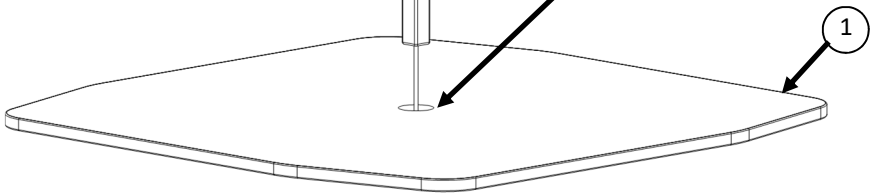

Marco Group, Inc.  
5400 Doniphan Dr.  
Neosho, MO 64850  
www.madebymarco.net

Customer Service Hours:  
Monday-Friday 8:30am to 4:30pm CST  
(Except holidays)  
Toll-Free 888-627-2601  
CustomerService@marcogroupinc.com

417-455-9663 - Phone  
417-455-0057 - Fax

1

Place cabinets '2' on flat level surface. Carefully align the four mount holes for each cabinet as shown and fasten with four cap nuts 'B' and bolts 'C'. Repeat until all four cabinets are assembled as one unit.

**NOTE:** Careful alignment of the cabinets is important to ensure tabletop alignment in a later step.

**NOTE:** Plastic trays will need to be removed to gain access to fastener locations. Doors **DO NOT** need to be removed and only shown removed in this step for visual clarity.

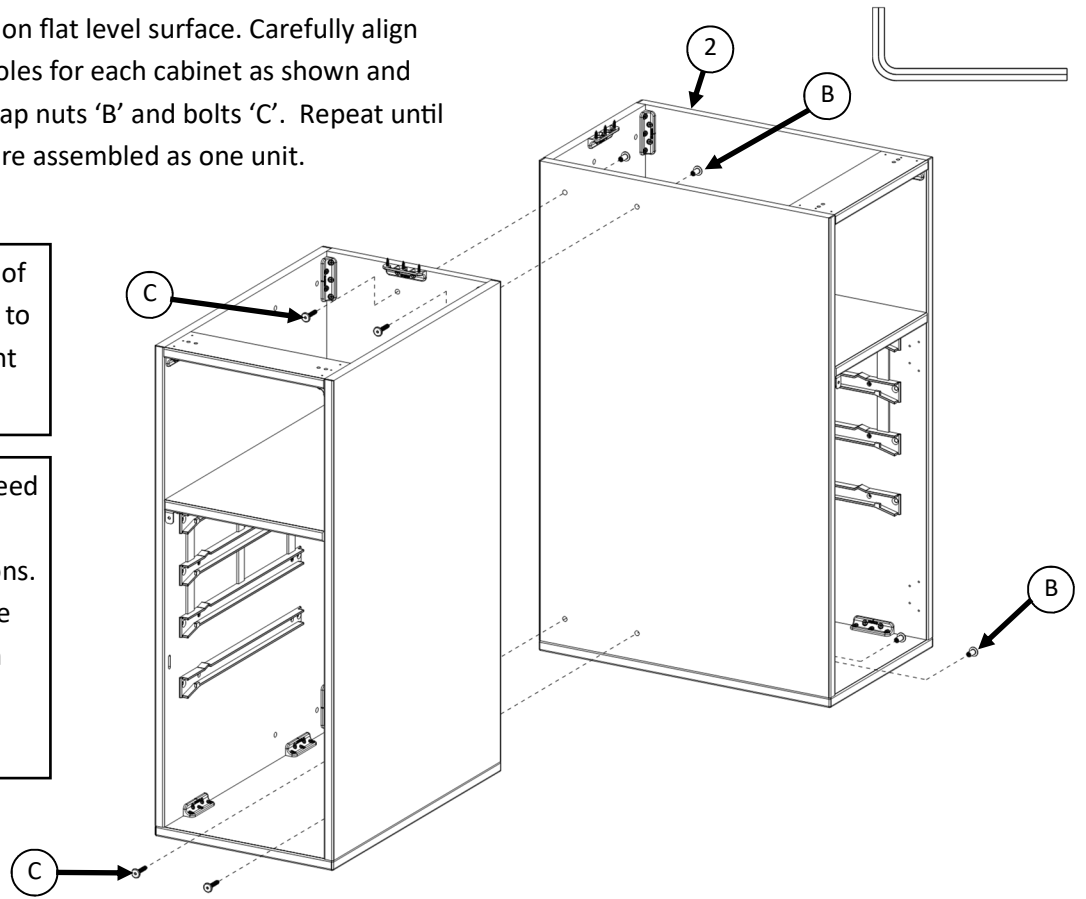

2

Attach casters '3' to cabinets with four bolts 'D' per caster.

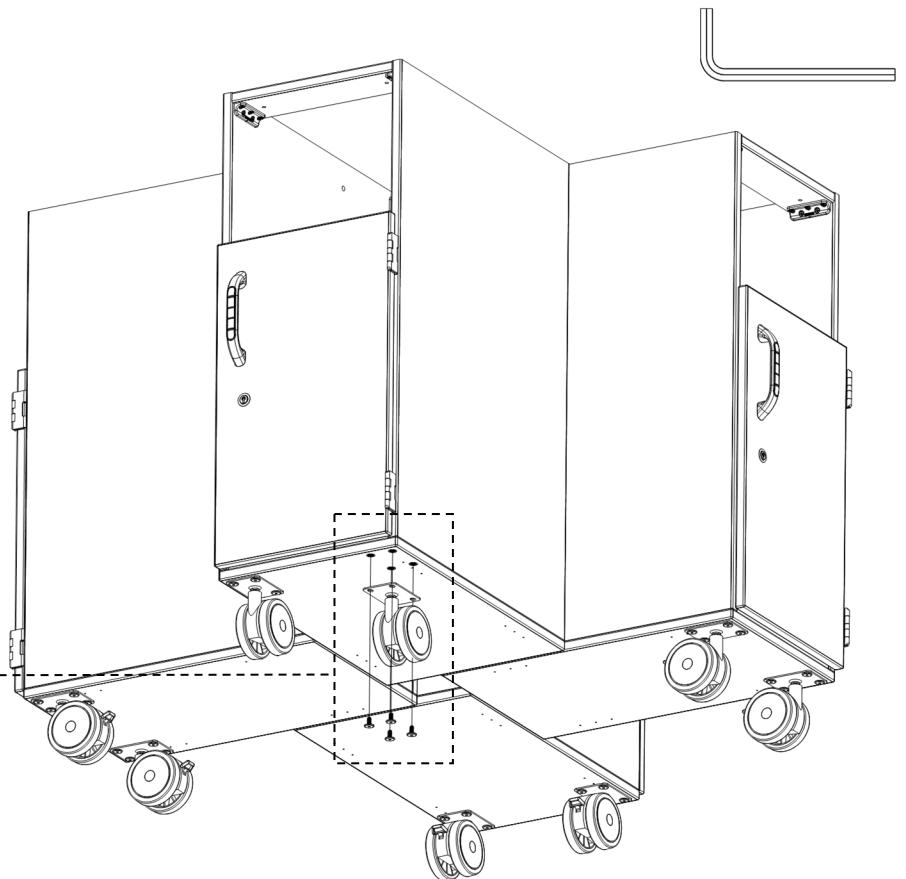
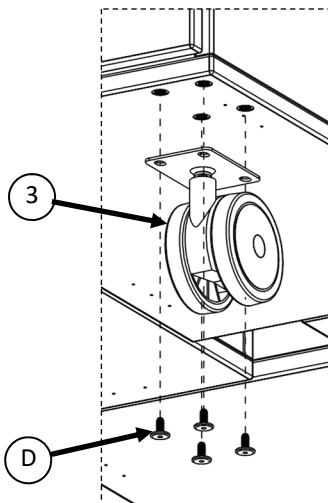

3

### OPTIONAL STEP FOR POWER MODULE OPTION

Insert power module '4' into hole at center of tabletop. On underside thread on plastic nut to secure module to tabletop.

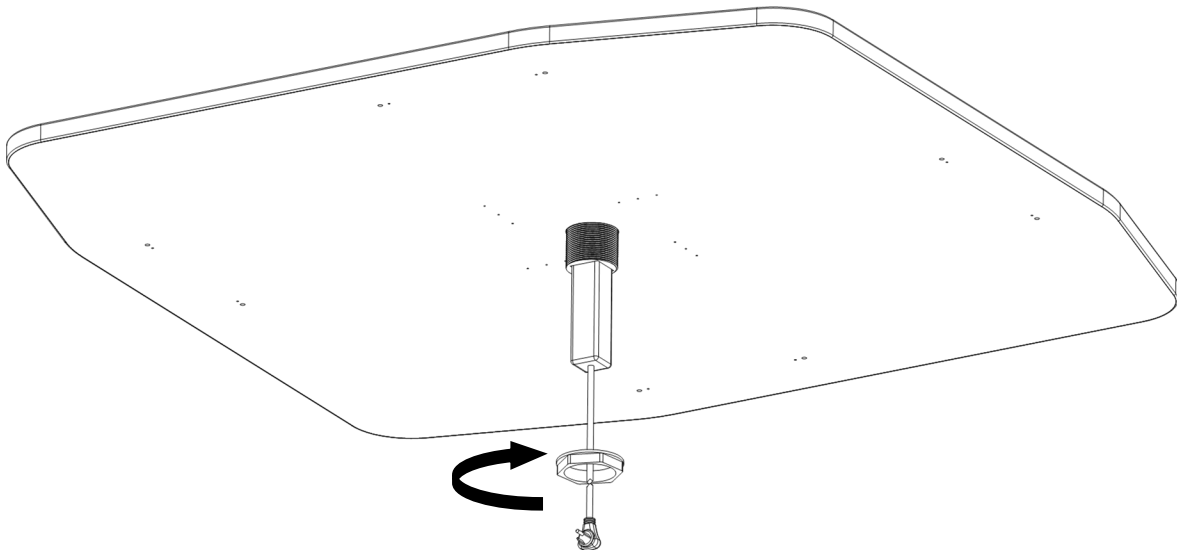
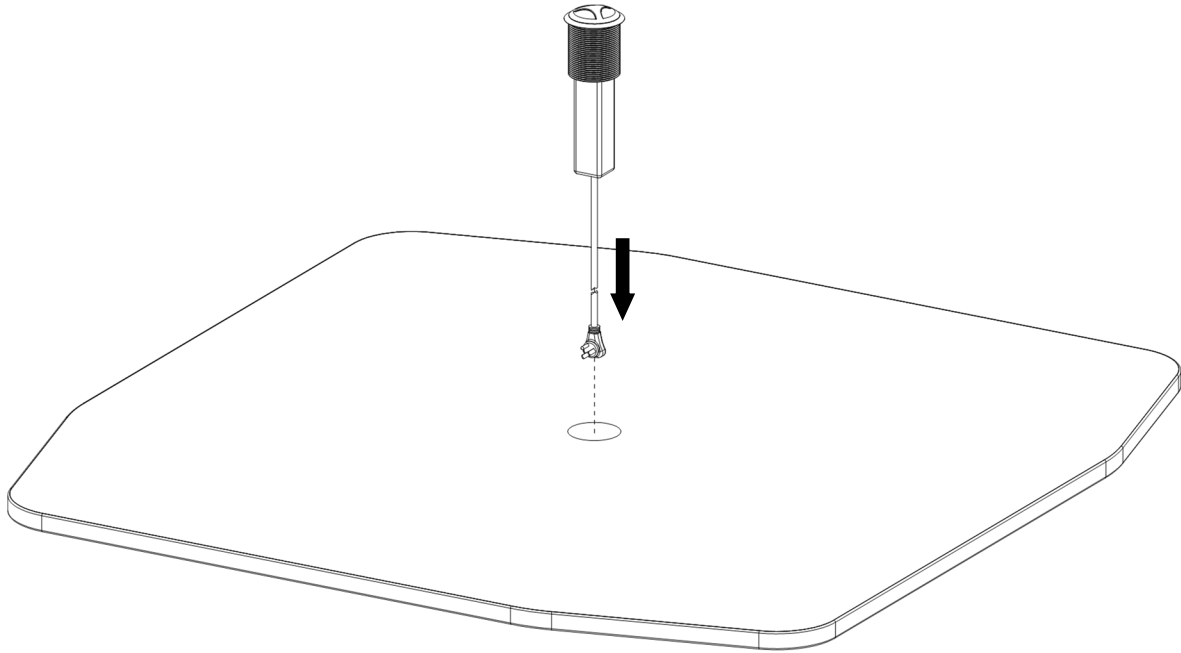

4

Insert eight wood dowels 'E' into the outer holes of the cabinet cross brace, two dowels per cabinet.

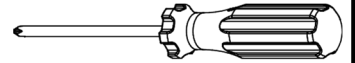

Place table top onto cabinets and align the wood dowels to the predrilled holes in the top. If there are any misalignments of the dowels adjustment of the cabinets may be necessary. Refer back to Step 1.

Attach top to cabinets using eight screws 'F' through predrilled holes in cabinet cross brace, two screws per cabinet.

Attach top at rear of each cabinet using three screws 'A' through fastener block on each cabinet.

