



Assembly Instructions

#85286

LF Tabletop Mounting

Rev. 01-06-26

Tools required

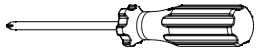

#2 Phillips Screwdriver

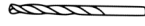
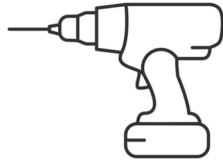

3/32" Drill bit

Hardware (Included)

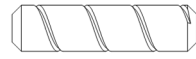

1/4" x 1" Wood Dowel

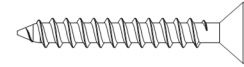

#10 x 1-1/2" Screw



STEP 1 Place sub-top on base with hole counterbores facing up and center/align center cutouts so the attachment holes are directly over the base wood structure. Drill 3/32" pilot holes into the base through counterbored holes and screw sub-top to base with screw (B) as shown.

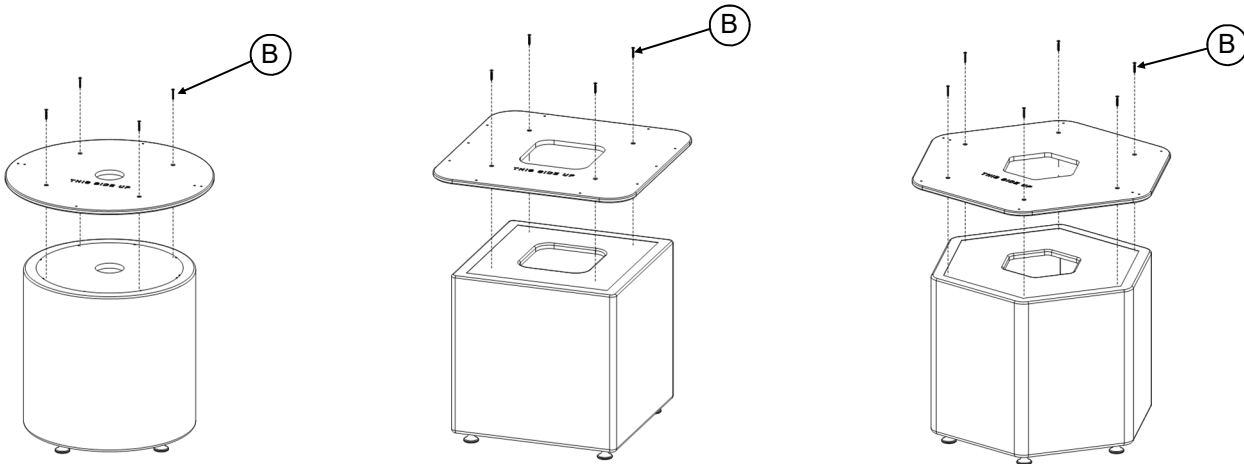

STEP 2

Insert (2) wood dowels into the 1/4" diameter holes as shown which are **NOT** drilled all the way through. Place table top onto sub-top and align the wood dowels with the 1/4" holes drilled in the table top. Attach top to sub-top with screw "B" through pre-drilled holes as shown - (4) on the round top, (8) on the square top, & (6) on hex top.

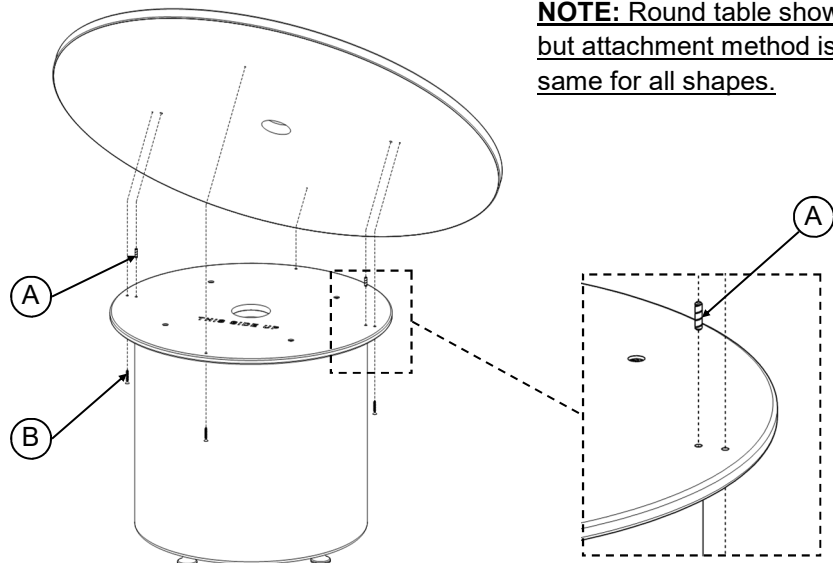

NOTE: Round table shown but attachment method is the same for all shapes.

Marco Group, Inc.
5400 Doniphan Dr.
Neosho, MO 64850
www.madebymarco.net

Customer Service Hours:
Monday-Friday 8:30am to 4:30pm CST
(Except holidays)
Toll-Free 888-627-2601
CustomerService@marcogroupinc.com

417-455-9663 - Phone
417-455-0057 - Fax