

### Tools required

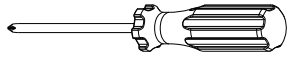

Phillips screwdriver



Drill

 3mm Drill Bit  
Included

### Hardware (Included)

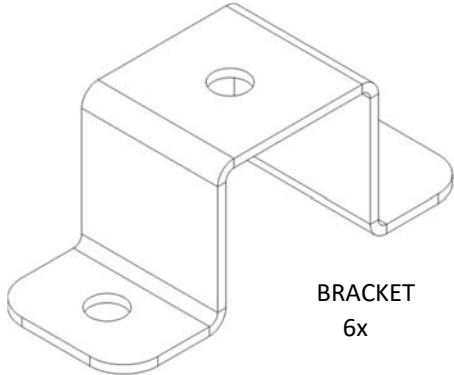
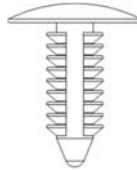
 BRACKET  
6x

 PUSH PIN  
6x

 SCREW  
12x

**1**

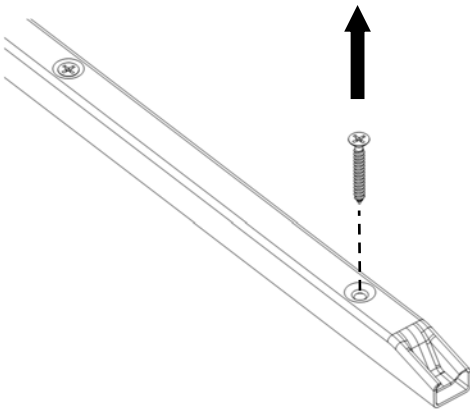
Remove existing screw from support bar and discard.

**2**

With support bar aligned with original location place bracket over bar and insert plastic push pin through the center bracket hole and into the support bar. Mark new screw locations with a pencil or marker using bracket as a guide. Drill pilot holes with supplied drill bit **1/2"** deep. **DO NOT DRILL DEEPER THAN 1/2"**.

Attach bracket to table top with supplied screws. Repeat for all brackets at each support bar hole location.

